

Do not scale / / Resim üzerinden ölçü almayınız / The dimensions, other than given in our web-site and catalogs are subject to change without prior notice. / Katalog ve web sitelerimizde verilenler dışındaki ölçüler haber vermeksizin değiştirilebilir.

M	F	H	TL	SW	O-RING
M20x1.5	M16x1.5	19,0	15,0	25,0	Ø16x1.5
M25x1.5	M16x1.5	19,0	15,0	30,0	Ø22x2.0
M25x1.5	M20x1.5	19,0	15,0	30,0	Ø22x2.0
M32x1.5	M16x1.5	19,0	15,0	36,0	Ø26x2.0
M32x1.5	M20x1.5	19,0	15,0	36,0	Ø26x2.0
M32x1.5	M25x1.5	19,0	15,0	36,0	Ø26x2.0
M40x1.5	M16x1.5	22,0	18,0	45,0	Ø35x2.0
M40x1.5	M20x1.5	22,0	18,0	45,0	Ø35x2.0
M40x1.5	M25x1.5	22,0	18,0	45,0	Ø35x2.0
M40x1.5	M32x1.5	22,0	18,0	45,0	Ø35x2.0
M50x1.5	M16x1.5	23,0	18,0	55,0	Ø45x2.0
M50x1.5	M20x1.5	23,0	18,0	55,0	Ø45x2.0
M50x1.5	M25x1.5	23,0	18,0	55,0	Ø45x2.0
M50x1.5	M32x1.5	23,0	18,0	55,0	Ø45x2.0
M50x1.5	M40x1.5	23,0	18,0	55,0	Ø45x2.0
M60x1.5	M16x1.5	23,0	18,0	70,0	Ø54x2.6
M60x1.5	M20x1.5	23,0	18,0	70,0	Ø54x2.6
M60x1.5	M25x1.5	23,0	18,0	70,0	Ø54x2.6
M60x1.5	M32x1.5	23,0	18,0	70,0	Ø54x2.6
M60x1.5	M40x1.5	23,0	18,0	70,0	Ø54x2.6
M60x1.5	M50x1.5	23,0	18,0	70,0	Ø54x2.6
M63x1.5	M16x1.5	23,0	18,0	70,0	Ø54x2.6
M63x1.5	M20x1.5	23,0	18,0	70,0	Ø54x2.6
M63x1.5	M25x1.5	23,0	18,0	70,0	Ø54x2.6
M63x1.5	M32x1.5	23,0	18,0	70,0	Ø54x2.6
M63x1.5	M40x1.5	23,0	18,0	70,0	Ø54x2.6
M63x1.5	M50x1.5	23,0	18,0	70,0	Ø54x2.6
M70x1.5	M16x1.5	24,0	18,0	80,0	Ø65x2.5
M70x1.5	M20x1.5	24,0	18,0	80,0	Ø65x2.5
M70x1.5	M25x1.5	24,0	18,0	80,0	Ø65x2.5
M70x1.5	M32x1.5	24,0	18,0	80,0	Ø65x2.5
M70x1.5	M40x1.5	24,0	18,0	80,0	Ø65x2.5
M70x1.5	M50x1.5	24,0	18,0	80,0	Ø65x2.5
M70x1.5	M60x1.5	24,0	18,0	80,0	Ø65x2.5
M70x1.5	M63x1.5	24,0	18,0	80,0	Ø65x2.5
M75x1.5	M20x1.5	24,0	18,0	85,0	Ø68x2.6
M75x1.5	M25x1.5	24,0	18,0	85,0	Ø68x2.6
M75x1.5	M32x1.5	24,0	18,0	85,0	Ø68x2.6
M75x1.5	M40x1.5	24,0	18,0	85,0	Ø68x2.6
M75x1.5	M50x1.5	24,0	18,0	85,0	Ø68x2.6
M75x1.5	M60x1.5	24,0	18,0	85,0	Ø68x2.6
M75x1.5	M63x1.5	24,0	18,0	85,0	Ø68x2.6

M	F	H	TL	SW	O-RING
M80x1.5	M25x1.5	24,0	18,0	90,0	Ø75x2.5
M80x1.5	M32x1.5	24,0	18,0	90,0	Ø75x2.5
M80x1.5	M40x1.5	24,0	18,0	90,0	Ø75x2.5
M80x1.5	M50x1.5	24,0	18,0	90,0	Ø75x2.5
M80x1.5	M60x1.5	24,0	18,0	90,0	Ø75x2.5
M80x1.5	M60x2.0	24,0	18,0	90,0	Ø75x2.5
M80x1.5	M63x1.5	24,0	18,0	90,0	Ø75x2.5
M80x1.5	M70x1.5	24,0	18,0	90,0	Ø75x2.5
M80x1.5	M75x1.5	24,0	18,0	90,0	Ø75x2.5
M85x1.5	M25x1.5	29,0	21,0	95,0	Ø80x3.0
M85x1.5	M32x1.5	29,0	21,0	95,0	Ø80x3.0
M85x1.5	M40x1.5	29,0	21,0	95,0	Ø80x3.0
M85x1.5	M50x1.5	29,0	21,0	95,0	Ø80x3.0
M85x1.5	M60x1.5	29,0	21,0	95,0	Ø80x3.0
M85x1.5	M63x1.5	29,0	21,0	95,0	Ø80x3.0
M85x1.5	M70x1.5	29,0	21,0	95,0	Ø80x3.0
M85x1.5	M75x1.5	29,0	21,0	95,0	Ø80x3.0
M90x1.5	M25x1.5	29,0	21,0	100,0	Ø83x3.0
M90x1.5	M32x1.5	29,0	21,0	100,0	Ø83x3.0
M90x1.5	M40x1.5	29,0	21,0	100,0	Ø83x3.0
M90x1.5	M50x1.5	29,0	21,0	100,0	Ø83x3.0
M90x1.5	M60x1.5	29,0	21,0	100,0	Ø83x3.0
M90x1.5	M63x1.5	29,0	21,0	100,0	Ø83x3.0
M90x1.5	M70x1.5	29,0	21,0	100,0	Ø83x3.0
M90x1.5	M75x1.5	29,0	21,0	100,0	Ø83x3.0
M100x1.5	M32x1.5	31,0	21,0	110,0	Ø95x3.0
M100x1.5	M40x1.5	31,0	21,0	110,0	Ø95x3.0
M100x1.5	M50x1.5	31,0	21,0	110,0	Ø95x3.0
M100x1.5	M60x1.5	31,0	21,0	110,0	Ø95x3.0
M100x1.5	M63x1.5	31,0	21,0	110,0	Ø95x3.0
M100x1.5	M70x1.5	31,0	21,0	110,0	Ø95x3.0
M100x1.5	M75x1.5	31,0	21,0	110,0	Ø95x3.0
M100x1.5	M80x1.5	31,0	21,0	110,0	Ø95x3.0
M100x1.5	M85x1.5	31,0	21,0	110,0	Ø95x3.0
M100x1.5	M90x1.5	31,0	21,0	110,0	Ø95x3.0
M110x1.5	M40x1.5	31,0	21,0	120,0	Ø105x3.0
M110x1.5	M50x1.5	31,0	21,0	120,0	Ø105x3.0
M110x1.5	M63x1.5	31,0	21,0	120,0	Ø105x3.0
M110x1.5	M75x1.5	31,0	21,0	120,0	Ø105x3.0
M110x1.5	M90x1.5	31,0	21,0	120,0	Ø105x3.0
M110x1.5	M100x1.5	31,0	21,0	120,0	Ø105x3.0

M	F	H	TL	SW	O-RING
M20x1.5	NPT 3/8"	19,0	15,0	25,0	Ø16x1.5
M25x1.5	NPT 3/8"	19,0	15,0	30,0	Ø22x2.0
M25x1.5	NPT 1/2"	19,0	15,0	30,0	Ø22x2.0
M32x1.5	NPT 3/8"	19,0	15,0	36,0	Ø26x2.0
M32x1.5	NPT 1/2"	19,0	15,0	36,0	Ø26x2.0
M32x1.5	NPT 3/4"	19,0	15,0	36,0	Ø26x2.0
M40x1.5	NPT 3/8"	22,0	18,0	45,0	Ø35x2.0
M40x1.5	NPT 1/2"	22,0	18,0	45,0	Ø35x2.0
M40x1.5	NPT 3/4"	22,0	18,0	45,0	Ø35x2.0
M40x1.5	NPT 1"	22,0	18,0	45,0	Ø35x2.0
M50x1.5	NPT 3/8"	23,0	18,0	55,0	Ø45x2.0
M50x1.5	NPT 1/2"	23,0	18,0	55,0	Ø45x2.0
M50x1.5	NPT 3/4"	23,0	18,0	55,0	Ø45x2.0
M50x1.5	NPT 1"	23,0	18,0	55,0	Ø45x2.0
M50x1.5	NPT 1 1/4"	23,0	18,0	55,0	Ø45x2.0
M60x1.5	NPT 3/8"	23,0	18,0	70,0	Ø54x2.6
M60x1.5	NPT 1/2"	23,0	18,0	70,0	Ø54x2.6
M60x1.5	NPT 3/4"	23,0	18,0	70,0	Ø54x2.6
M60x1.5	NPT 1"	23,0	18,0	70,0	Ø54x2.6
M60x1.5	NPT 1 1/4"	23,0	18,0	70,0	Ø54x2.6
M60x1.5	NPT 1 1/2"	23,0	18,0	70,0	Ø54x2.6
M63x1.5	NPT 3/8"	23,0	18,0	70,0	Ø54x2.6
M63x1.5	NPT 1/2"	23,0	18,0	70,0	Ø54x2.6
M63x1.5	NPT 3/4"	23,0	18,0	70,0	Ø54x2.6
M63x1.5	NPT 1"	23,0	18,0	70,0	Ø54x2.6
M63x1.5	NPT 1 1/4"	23,0	18,0	70,0	Ø54x2.6
M63x1.5	NPT 1 1/2"	23,0	18,0	70,0	Ø54x2.6
M70x1.5	NPT 3/8"	24,0	18,0	80,0	Ø65x2.5
M70x1.5	NPT 1/2"	24,0	18,0	80,0	Ø65x2.5
M70x1.5	NPT 3/4"	24,0	18,0	80,0	Ø65x2.5
M70x1.5	NPT 1"	24,0	18,0	80,0	Ø65x2.5
M70x1.5	NPT 1 1/4"	24,0	18,0	80,0	Ø65x2.5
M70x1.5	NPT 1 1/2"	24,0	18,0	80,0	Ø65x2.5
M75x1.5	NPT 1/2"	24,0	18,0	85,0	Ø68x2.6
M75x1.5	NPT 3/4"	24,0	18,0	85,0	Ø68x2.6
M75x1.5	NPT 1"	24,0	18,0	85,0	Ø68x2.6
M75x1.5	NPT 1 1/4"	24,0	18,0	85,0	Ø68x2.6
M75x1.5	NPT 1 1/2"	24,0	18,0	85,0	Ø68x2.6
M75x1.5	NPT 2"	24,0	18,0	85,0	Ø68x2.6

M	F	H	TL	SW	O-RING
M80x1.5	NPT 3/4"	24,0	18,0	90,0	Ø75x2.5
M80x1.5	NPT 1"	24,0	18,0	90,0	Ø75x2.5
M80x1.5	NPT 1 1/4"	24,0	18,0	90,0	Ø75x2.5
M80x1.5	NPT 1 1/2"	24,0	18,0	90,0	Ø75x2.5
M80x1.5	NPT 2"	24,0	18,0	90,0	Ø75x2.5
M80x1.5	NPT 2 1/2"	24,0	18,0	90,0	Ø75x2.5
M85x1.5	NPT 3/4"	29,0	21,0	95,0	Ø80x3.0
M85x1.5	NPT 1"	29,0	21,0	95,0	Ø80x3.0
M85x1.5	NPT 1 1/4"	29,0	21,0	95,0	Ø80x3.0
M85x1.5	NPT 1 1/2"	29,0	21,0	95,0	Ø80x3.0
M85x1.5	NPT 2"	29,0	21,0	95,0	Ø80x3.0
M85x1.5	NPT 2 1/2"	29,0	21,0	95,0	Ø80x3.0
M90x1.5	NPT 3/4"	29,0	21,0	100,0	Ø83x3.0
M90x1.5	NPT 1"	29,0	21,0	100,0	Ø83x3.0
M90x1.5	NPT 1 1/4"	29,0	21,0	100,0	Ø83x3.0
M90x1.5	NPT 1 1/2"	29,0	21,0	100,0	Ø83x3.0
M90x1.5	NPT 2"	29,0	21,0	100,0	Ø83x3.0
M90x1.5	NPT 2 1/2"	29,0	21,0	100,0	Ø83x3.0
M100x1.5	NPT 1"	31,0	21,0	110,0	Ø95x3.0
M100x1.5	NPT 1 1/4"	31,0	21,0	110,0	Ø95x3.0
M100x1.5	NPT 1 1/2"	31,0	21,0	110,0	Ø95x3.0
M100x1.5	NPT 2"	31,0	21,0	110,0	Ø95x3.0
M100x1.5	NPT 2 1/2"	31,0	21,0	110,0	Ø95x3.0
M100x1.5	NPT 3"	31,0	21,0	110,0	Ø95x3.0
M110x1.5	NPT 1 1/4"	31,0	21,0	120,0	Ø105x3.0
M110x1.5	NPT 1 1/2"	31,0	21,0	120,0	Ø105x3.0
M110x1.5	NPT 2"	31,0	21,0	120,0	Ø105x3.0
M110x1.5	NPT 2 1/2"	31,0	21,0	120,0	Ø105x3.0
M110x1.5	NPT 3"	31,0	21,0	120,0	Ø105x3.0
M110x1.5	NPT 3 1/2"	31,0	21,0	120,0	Ø105x3.0

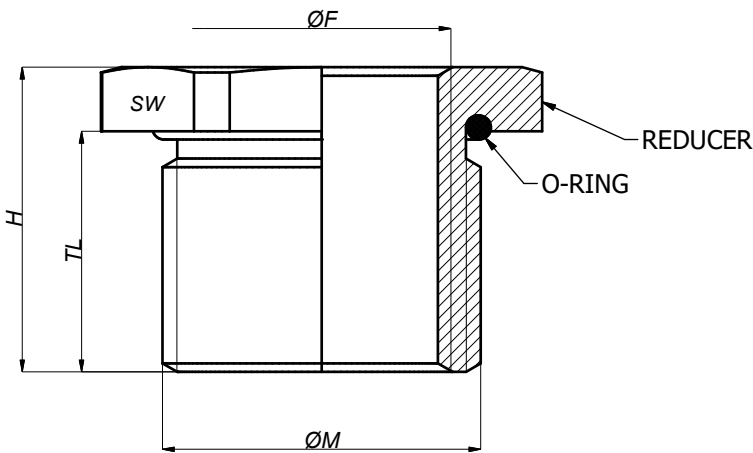
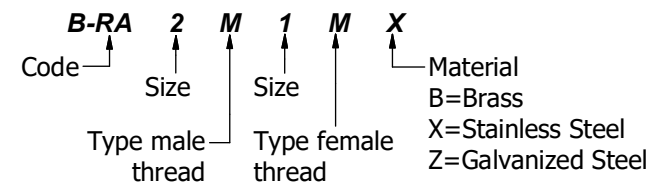

Revision History / Revizyon Tarihi					
No Nu.	Date Tarih	Request No Talep Nu.	Revision Revizyon	Realised By Gerçekleştiren	Approved By Onaylayan
2	17.02.2020	2859	M80x1.5/M75x1.5 size has been added into the table. M80x1.5/M75x1.5 ebadı tabloya eklendi.	K.SERT	N.ORAL

Threads Type	Sizes															
	M	01	1	2	3	4	5	60	60x2.0	6	70	75	80	85	8	9
ISO 965-3	(16)	(20)	(25)	(32)	(40)	(50)	(60)	(62)	(63)	(70)	(75)	(80)	(85)	(90)	(100)	(110)
NPT ANSI B1.20.1	(3/8")	(1/2")	(3/4")	(1")	(1 1/4")	(1 1/2")	-	-	(2")	-	(2 1/2")	-	-	(3")	(3 1/2")	(4")
C	01	1	2	3	4	5	-	-	(2")	-	7	-	-	(3")	(3 1/2")	(4")
PF JIS B0202	(3/8")	(1/2")	(3/4")	(1")	(1 1/4")	(1 1/2")	-	-	(2")	-	(2 1/2")	-	-	(3")	(3 1/2")	(4")
P	2	3	4	5	6	7	-	-	8	-	9	-	-	10	-	-
PG DIN 40430	(9)	(11)	(13.5)	(16)	(21)	(29)	-	-	(36)	-	(42)	-	-	(48)	-	-

Drawing Number / Resim No	6948	Reference Number / Ref. No	A3-IEC-80-1	Date / Tarih	
1st Disc./Request #/Y.Yn.Tal.No	16-152	Designed by / Tasarlayan	Nursel ORAL	15.03.2016	
Bimed Code / Bimed Kodu	B-RA	Approved by / Onaylayan	Oğuz ELÇİ	15.03.2016	
MM and M/NPT IECEx Ex db IIC Ex eb IICREDUCER DIMENSION TABLE			Material / Malzeme		
M/M ve M/NPT SERİSİ IECEX Ex db IIC Ex eb IIC REDÜKSİYON ÖLÇÜ TABLOSU			MS 58 - (316-316L)		
			Brass(Nickel Plated)- Steel(Galvanized Plated) - Stainless		
			Pirinç(Nikel Kaplı) - Ç		